

# KVP® Straight 2" Pitch Belting HDU620 ST (Solid Top)

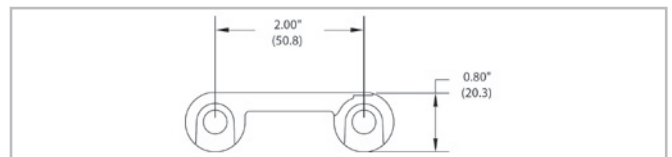

## Description

- 2 inch pitch
- Solid top surface
- Food approved materials
- Bi-directional
- Connecting rod diameter = 0.312 inch (7.9 mm)
- Standard belt width increments = 1 inch (25.4 mm) nominal, starting from 4 inches (101.6 mm)
- Material selection may affect belt width — please contact your local partner for actual dimensions

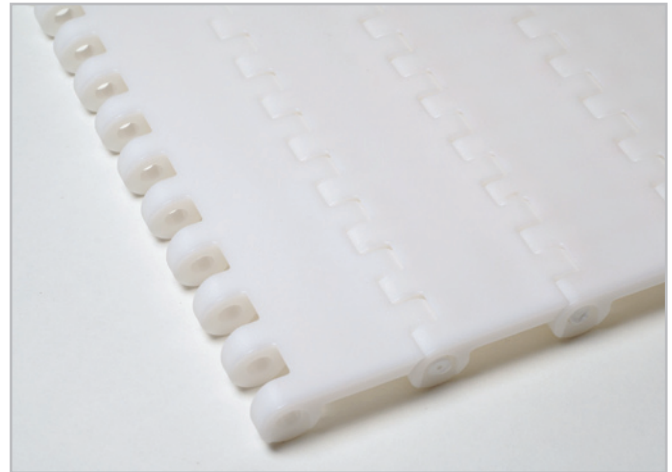

## Belt data

Belt material		PP	PP +DE	PE	POM	Nylon (PA 66)	Nylon (PA +IM)
Rod material		PP		PE			
Nominal tensile strength $F'_N$ straight run	N/m	26268	21010	20430	30646	30646	30646
	lb/ft	1800	1440	1400	2100	2100	2100
Temperature range	°C	5 - 105	5 - 105	-70 - 65	-40 - 65	-40 - 65	-40 - 80
	°F	40 - 220	40 - 220	-94 - 150	-40 - 150	-40 - 150	-40 - 176
Belt weight $m_B$	kg/m <sup>2</sup>	7.8	6.2	8.0	11.5	10.0	10.0
	lb/sqft	1.59	1.27	1.64	2.35	2.05	2.05
Standard belt color		white/gray/ blue	dark gray	blue/white	blue/white	gray/white	cream

Additional belt colors and materials available, abrasive resistant Nylon (Polyamide) rods available – contact your local partner.

## Belt accessories

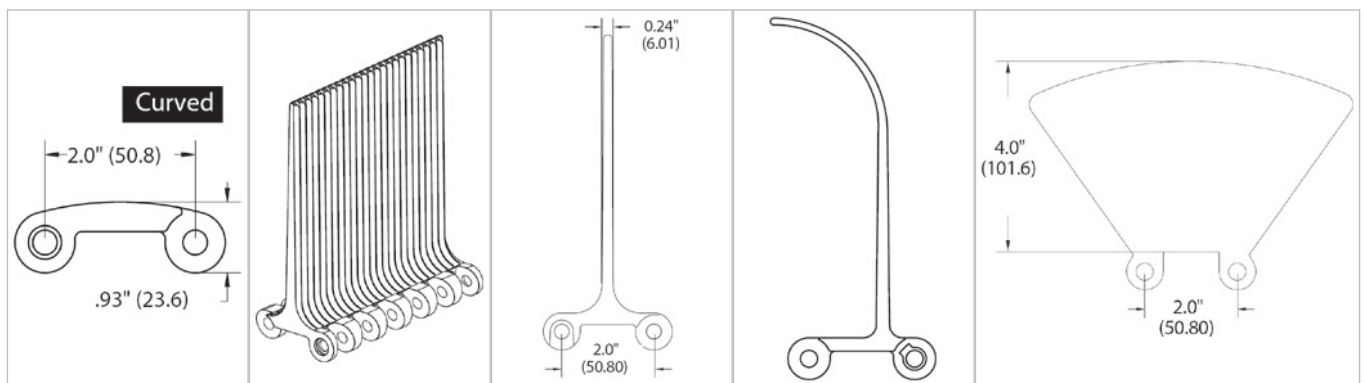

### High friction insert

Note: High friction inserts may affect belt pull — please contact your local partner.

### Easy release flight

Note: Available in 6" height only — all other dimensions are the same as rough duty flight.

### Rough duty flight

Rough duty flights available in standard 2", 4" & 6" heights.

### Curved flight

Curved flights available in standard 4" & 6" heights.

### Sideplate

Sideplates are available in standard 2", 3" & 4" heights. Please contact your local partner for indent specifications.

# KVP® Straight 2" Pitch Belting HDU620 ST (Solid Top)



## **Product liability, application considerations**

If the proper selection and application of Habasit products are not recommended by an authorized Habasit sales specialist, the selection and application of Habasit products, including the related area of product safety, are the responsibility of the customer.

All indications / information are recommendations and believed to be reliable, but no representations, guarantees, or warranties of any kind are made as to their accuracy or suitability for particular applications. The data provided herein are based on laboratory work with small-scale test equipment, running at standard conditions, and do not necessarily match product performance in industrial use. New knowledge and experiences can lead to modifications and changes within a short time without prior notice.

BECAUSE CONDITIONS OF USE ARE OUTSIDE OF HABASIT'S AND ITS AFFILIATED COMPANIES CONTROL, WE CANNOT ASSUME ANY LIABILITY CONCERNING THE SUITABILITY AND PROCESS ABILITY OF THE PRODUCTS MENTIONED HEREIN. THIS ALSO APPLIES TO PROCESS RESULTS / OUTPUT / MANUFACTURING GOODS AS WELL AS TO POSSIBLE DEFECTS, DAMAGES, CONSEQUENTIAL DAMAGES, AND FURTHER-REACHING CONSEQUENCES.