

Split Sprocket #882, 882-Tab

Material: Sprocket in reinforced polyamide (black).
Bolts in stainless steel AISI 304, nuts in nickel plated brass.

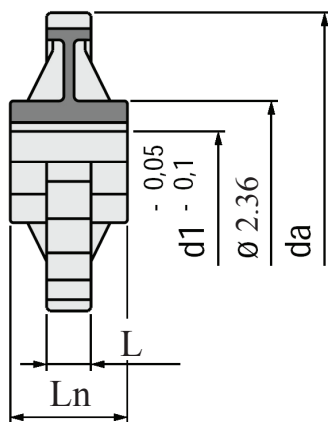

Chain #882-TAB

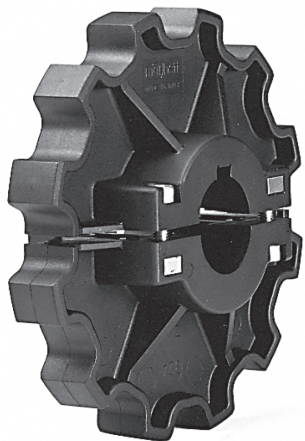
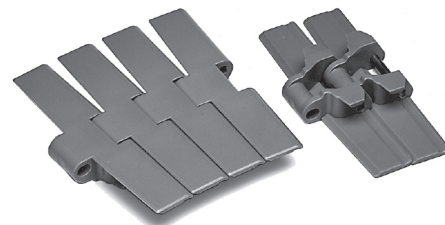

Part #	# Teeth	da	L	Ln	Bore d1
882-663601	12	5.90	0.874	2.30	1
882-619072	12	5.90	0.874	2.30	1-1/4
882-619082	12	5.90	0.874	2.30	1-1/2

Corner Tracks

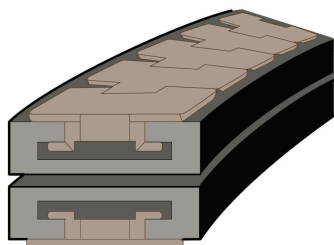

TAB type

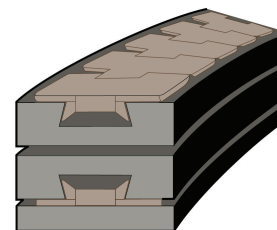
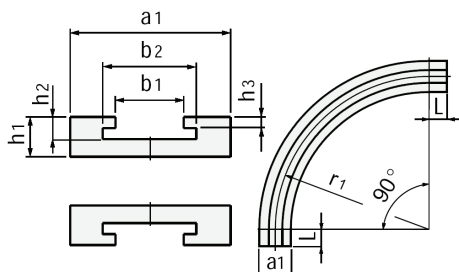

Bevel type

Materials

- **Black repro uhmw** : economical, wear resistant, Coef. 0.15/0.20
 - **Nylon MD** : high speed, long conveyors, heavy loads, Coef. 0.20
 - **Dry Lube** : wear resistant, no lubrication required, Coef. 0.10
 - **Oil filled** : Sticky, releases oil with friction, Coef. 0.06/0.12
- Contact CRS/VAMIC for more details.

Straight Tracks

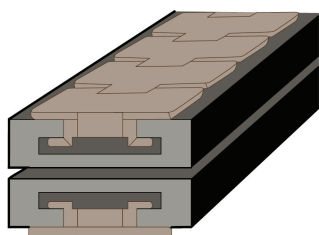

Straight tracks also available. Please specify length required.

HOW TO ORDER:

Specify :

- Chain Type and width (a) Ex: #882, 10"
- Style (b) Ex: Tab
- Radius dimension (c) Ex: 36"
- Number of lanes (d) Ex: Single lane
- Angle (e) Ex: 90°
- Material (f) Ex: Nylatron
- Thickness and width of track (g) Ex: 1-1/4" x 10-1/2"