

Description

- Solid sprocket 1150 is suitable for all 1150 series chains
- Bore configurations can be machined according to the customer requirements

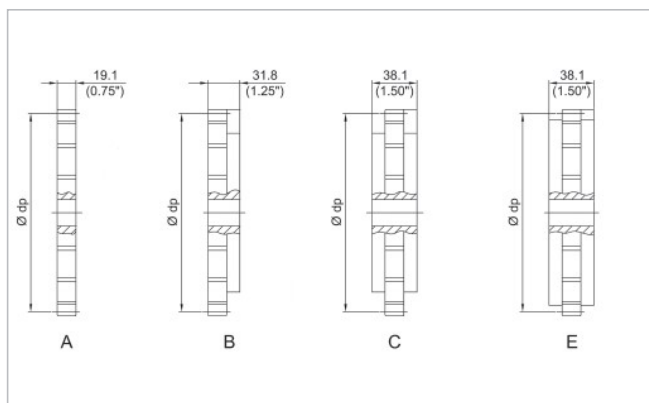

Sprocket data

Habasit code	Number of teeth	Diam. of pitch $\varnothing d_p$		Available hub type				Material
		mm	inch					
C1150M07PE	7	88.0	3.46	A	B	C		PE
C1150M09PE	9	112.0	4.41	A	B	C	E	PE
C1150M10PE	10	123.0	4.84	A	B	C	E	PE
C1150M12PE	12	147.0	5.79	A	B	C	E	PE
C1150M14PE	14	159.0	6.26	A	B	C	E	PE
C1150M15PE	15	183.0	7.20	A	B	C	E	PE
C1150M16PE	16	195.0	7.68	A	B	C	E	PE
C1150M17PE	17	207.0	8.15	A	B	C	E	PE

- Other materials available on request
- For hub type see nomenclature on page 9

- Available bore sizes:

Round [mm] 20, 25, 30, 35, 40

Round [inch] $\frac{3}{4}$, 1, 1 $\frac{3}{16}$, 1 $\frac{1}{4}$, 1 $\frac{1}{2}$

Square [mm] 25, 40

Square [inch] 1, 1 $\frac{1}{2}$