

KVP® Straight 1/2" Pitch Belting SM605 (Smooth Mesh)

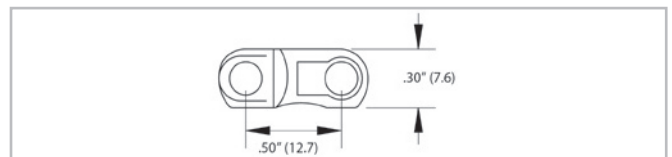

Description

- 1/2 inch pitch
- 30% open area
- Food approved materials
- Bi-directional
- 3/4 inch (19.1 mm) diameter nosebar capability
- Connecting rod diameter = 0.172 inch (4.4 mm)
- Standard belt width increments = 1 inch (25.4 mm) nominal, starting from 2 inches (50.8 mm)
- Non-standard widths available in 1/2 inch (12.7 mm) increments starting at 3 inches (76.2 mm) upon request
- Material selection may affect belt width — please contact your local partner for actual dimensions

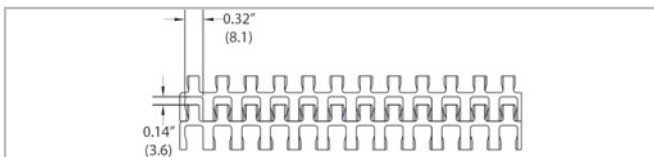
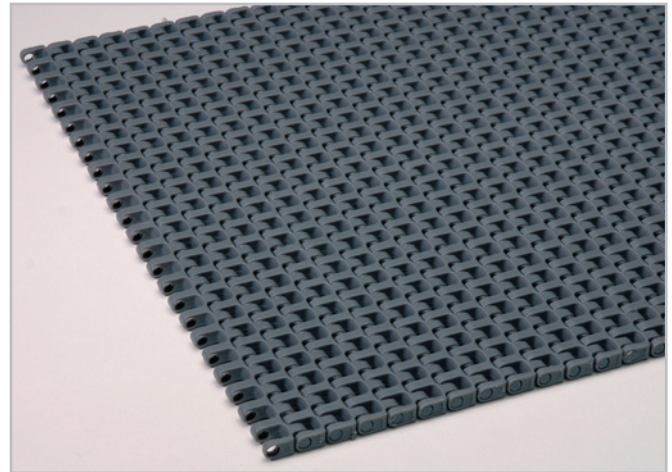

Belt data

Belt material		PP	PE	POM	Nylon (PA 66)	Nylon (PA +HN)
Rod material		PP	PE	PP	PP	Nylon (PA +GF)
Nominal tensile strength F'_N straight run	N/m lb/ft	11675 800	7005 480	20431 1400	20431 1400	10945 750
Temperature range	°C °F	5 - 105 40 - 220	-70 - 65 -94 - 150	5 - 93 40 - 200	5 - 105 40 - 220	-40 - 170 -40 - 338
Temperature maximum (short-term)	°C °F					200 392
Belt weight m_B	kg/m ² lb/sqft	4.2 0.86	4.4 0.91	6.1 1.25	5.2 1.06	5.2 1.06
Standard belt color		gray/white	white	blue/white	gray	maroon

Additional belt colors and materials available, abrasive resistant Nylon (Polyamide) rods available – contact your local partner.

Belt accessories

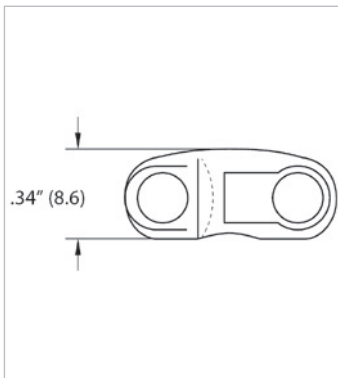

Inserts

Note: Inserts may affect belt pull - please contact your local partner.

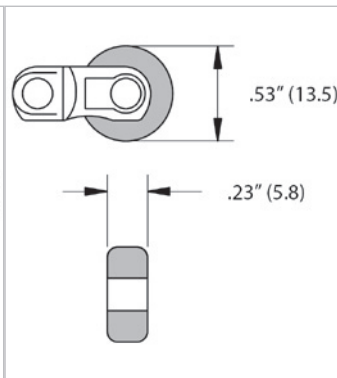

Rollers

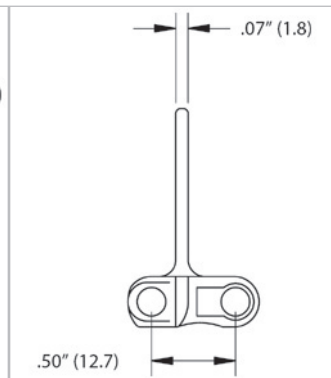

Flights

Standard flights are available in 1" (25.4 mm) height.

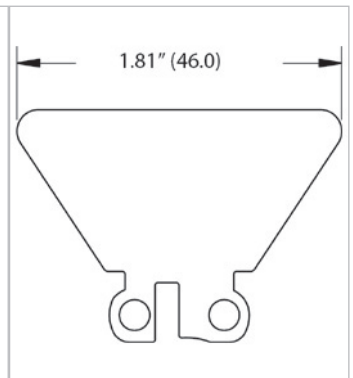

Sideplates

Sideplates are available in standard 1" (25.4 mm) height.

KVP® Straight 1/2" Pitch Belting SM605 (Smooth Mesh)



Product liability, application considerations

If the proper selection and application of Habasit products are not recommended by an authorized Habasit sales specialist, the selection and application of Habasit products, including the related area of product safety, are the responsibility of the customer.

All indications / information are recommendations and believed to be reliable, but no representations, guarantees, or warranties of any kind are made as to their accuracy or suitability for particular applications. The data provided herein are based on laboratory work with small-scale test equipment, running at standard conditions, and do not necessarily match product performance in industrial use. New knowledge and experiences can lead to modifications and changes within a short time without prior notice.

BECAUSE CONDITIONS OF USE ARE OUTSIDE OF HABASIT'S AND ITS AFFILIATED COMPANIES CONTROL, WE CANNOT ASSUME ANY LIABILITY CONCERNING THE SUITABILITY AND PROCESS ABILITY OF THE PRODUCTS MENTIONED HEREIN. THIS ALSO APPLIES TO PROCESS RESULTS / OUTPUT / MANUFACTURING GOODS AS WELL AS TO POSSIBLE DEFECTS, DAMAGES, CONSEQUENTIAL DAMAGES, AND FURTHER-REACHING CONSEQUENCES.