

HabasitLINK® Sprockets - 2" Pitch Belting

Sprocket Series M5100

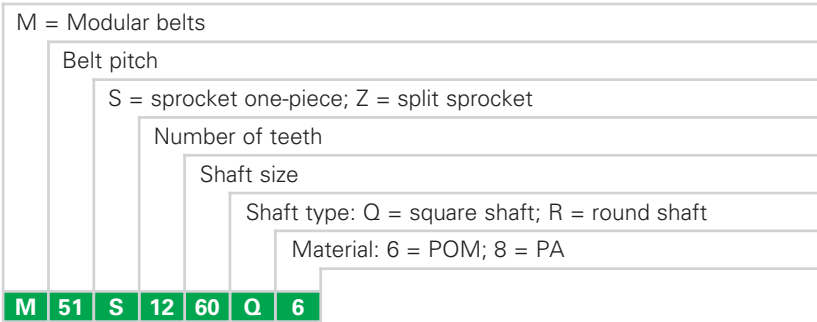

Sprocket availability

Type	Number of teeth	Diam. of pitch $\varnothing d_p$, A_1		Hub width B_L		Square bore Q		Ø Round bore R		Standard material		
		mm	inch	mm	inch	mm	inch	mm	inch			
S	16	261.5	10.3	122.8	4.83	45	1.77	90	3.5	-	-	POM
S-C1	10	165.2	6.5	74.6	2.94	30	1.18	40 / 60	1.5 / 2.5	40 / 50 / 60	1.5 / 2.5	POM
S-C1	12	197.2	7.8	90.6	3.57	30	1.18	40 / 60	1.5 / 2.5	40 / 60	1.5 / 2.5	POM
S-C1	13	213.2	8.4	98.6	3.88	30	1.18	40 / 60 / 90	1.5 / 2.5	40 / 60 / 90	1.5 / 2.5	POM
S-C1	16	261.5	10.3	122.8	4.83	40	1.57	60 / 90 / 120	1.5 / 2.5 / 3.5	60 / 90	1.5 / 2.5	POM

S: molded sprockets; S-C1: machined sprockets. Other sprocket and hub sizes on request.

Key ways for round bore shape follow European standards for metric sizes and US standards for imperial sizes. For detailed dimensions see table in the Design Guide.

Other materials available on request.

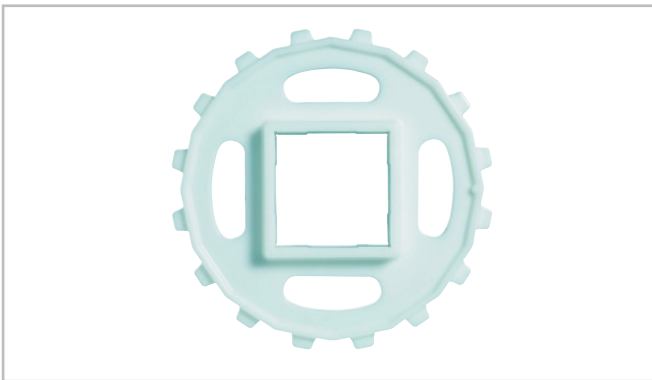

Sprocket one-piece ("open window")



Sprocket one-piece (solid)

HabasitLINK® Sprockets - 2" Pitch Belting

Sprocket Series M5100



Sprocket arrangement

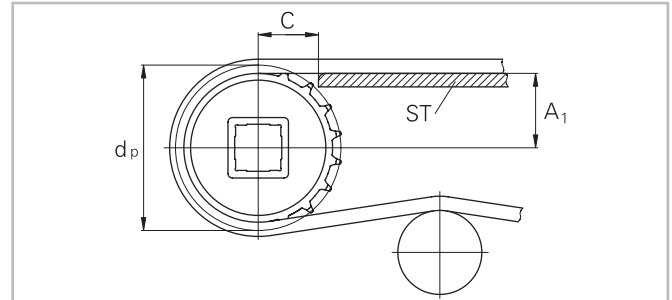
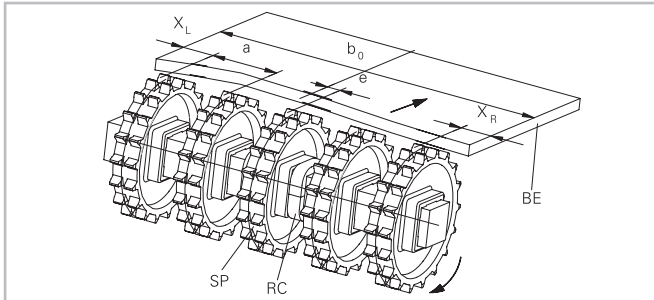

- BE** Belt
- RC** Retainer
- SP** Sprocket
- b₀** belt width

The distance **C** between the sprocket axis and the slider support **ST** is minimal 53 mm (2.1").

Wearstrips

Between driving shaft and idling sprockets or rollers the belt is carried by a slider support furnished with longitudinal wear strips from UHMW Polyethylene or other suitable material.

Sprocket positioning

For correct positioning of the center sprocket divide the belt width by the link increment. The rounded result will be an even or an odd number. These numbers are the criteria for offset or no offset, see table.

Belt type	Sprocket and support roller spacing a		Sprocket and support roller edge distance		Criteria for center sprocket position	Result of formula (rounded)	Offset e	Remarks
	minimal	maximal	X _L	X _R				
	mm inch	mm inch	mm inch	mm inch				
M5131	58.2 2.29	152.4 6	28 1.1	28 1.1	b ₀ / 38.1 b ₀ / 1.5	even number (2, 4, 6 ...)	9.5 0.38	right or left side
						odd number (3, 5, 7 ...)	9.5 0.38	right or left side
M5182-R9	50.8 2.0	101.6 4.0	25.4 1.0	25.4 1.0	b ₀ / 50.8 b ₀ / 2.0	even number (2, 4, 6 ...)	25.4 1.0	right or left side
						odd number (3, 5, 7 ...)	0 0	

HabasitLINK® Sprockets - 2" Pitch Belting

Sprocket Series M5100



Numbers of sprockets and wearstrips for M5131

Standard belt width (nominal)		Number of sprockets per shaft	Number of wearstrips	
mm	inch	min. number	Carryway (top)	Returnway (bottom)
229	9	2	2	2
305	12	2	2	2
381	15	3	3	3
457	18	3	3	3
533	21	3	3	3
610	24	3	4	3
686	27	5	4	3
762	30	5	4	4
838	33	5	5	4
914	36	5	5	4
991	39	7	5	4
1'067	42	7	6	4
1'143	45	7	6	5
1'219	48	7	7	5
1'295	51	9	7	5
1'372	54	9	7	5
1'448	57	9	7	5
1'524	60	9	8	6
1'600	63	11	8	6
1'676	66	11	8	6
1'753	69	11	8	6
1'829	72	11	9	6
1'905	75	13	9	7
1'981	78	13	9	7
2'057	81	13	9	7
2'134	84	13	10	7
2'210	87	15	10	7
2'286	90	15	10	8
2'515	99	17	11	8
2'743	108	17	12	9
2'972	117	19	12	9
3'200	126	21	13	10
3'429	135	23	14	11
3'658	144	23	15	11
3'810	150	25	15	12

The number of sprockets depends on the belt load and may be different for driving and idling shafts. For calculation of correct sprocket number please use LINK-SeleCalc.

HabasitLINK® Sprockets - 2" Pitch Belting

Sprocket Series M5100



Numbers of sprockets and wearstrips for M5182-R9

Standard belt width (nominal)		Number of sprockets per shaft		Number of wearstrips	
mm	<i>inch</i>	Drive shaft (loaded shaft)	Idling shaft (unloaded shaft)	Carryway (top)	Returnway (bottom)
152	6	3	2	3	2
203	8	4	2	4	2
254	10	5	3	5	3
305	12	6	3	6	3
356	14	7	4	7	4
406	16	8	4	8	4
457	18	9	5	9	5
508	20	10	5	10	5
559	22	11	6	11	6
610	24	12	6	12	6
660	26	13	7	13	7
711	28	14	7	14	7
762	30	15	8	15	8
813	32	16	8	16	8
864	34	17	9	17	9
914	36	18	9	18	9
965	38	19	10	19	10
1'016	40	20	10	20	10
1'067	42	21	11	21	11
1'118	44	22	11	22	11
1'168	46	23	12	23	12
1'219	48	24	12	24	12
1'270	50	25	13	25	13
1'321	52	26	13	26	13
1'372	54	27	14	27	14
1'422	56	28	14	28	14
1'473	58	29	15	29	15
1'524	60	30	15	30	15
1'575	62	31	16	31	16
1'626	64	32	16	32	16
1'676	66	33	17	33	17
1'727	68	34	17	34	17
1'778	70	35	18	35	18
1'829	72	36	18	36	18
1'880	74	37	19	37	19
1'930	76	38	19	38	19
1'981	78	39	20	39	20
2'032	80	40	20	40	20

The number of sprockets depends on the belt load and may be different for driving and idling shafts. For calculation of correct sprocket number please use LINK-SeleCalc.

HabasitLINK® Sprockets - 2" Pitch Belting Sprocket Series M5100



Product liability, application considerations

If the proper selection and application of Habasit products are not recommended by an authorized Habasit sales specialist, the selection and application of Habasit products, including the related area of product safety, are the responsibility of the customer.

All indications / information are recommendations and believed to be reliable, but no representations, guarantees, or warranties of any kind are made as to their accuracy or suitability for particular applications. The data provided herein are based on laboratory work with small-scale test equipment, running at standard conditions, and do not necessarily match product performance in industrial use. New knowledge and experiences can lead to modifications and changes within a short time without prior notice.

BECAUSE CONDITIONS OF USE ARE OUTSIDE OF HABASIT'S AND ITS AFFILIATED COMPANIES CONTROL, WE CANNOT ASSUME ANY LIABILITY CONCERNING THE SUITABILITY AND PROCESS ABILITY OF THE PRODUCTS MENTIONED HEREIN. THIS ALSO APPLIES TO PROCESS RESULTS / OUTPUT / MANUFACTURING GOODS AS WELL AS TO POSSIBLE DEFECTS, DAMAGES, CONSEQUENTIAL DAMAGES, AND FURTHER-REACHING CONSEQUENCES.