

TM127 SERIES (5.0" diameter)

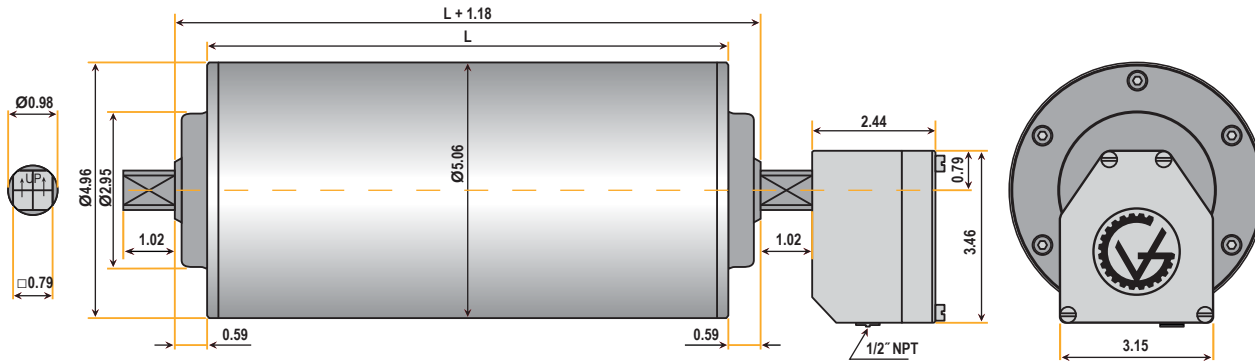

DIMENSIONS (in inches)

TM127A25 Drum Motor (matching Idler KT127A25**)



Standard face widths* (L) in inches:

9.84	10.83	11.81	13.78	15.75	17.72	19.69	21.65	23.62
25.59	27.56	29.53	31.50	33.46	35.43	37.40	39.37	41.34
43.31	45.28	47.24						

TM127B25 Drum Motor (matching Idler KT127B25**)

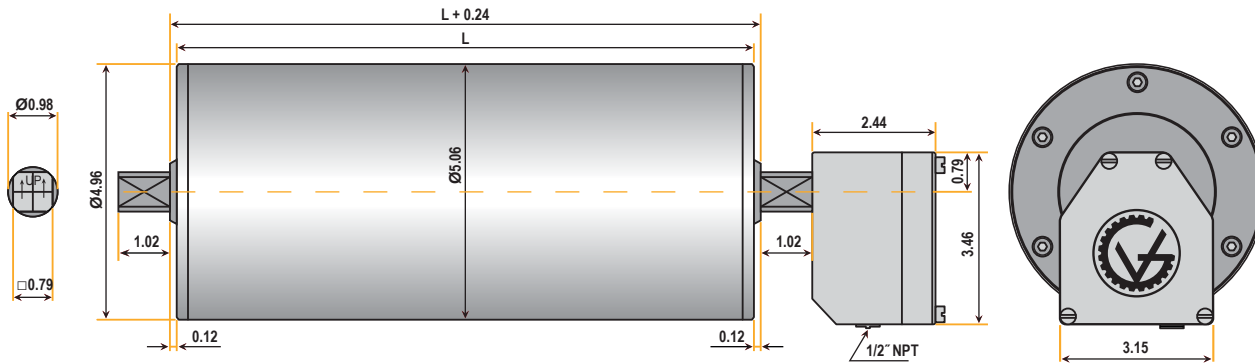

Standard face widths* (L) in inches:

10.83	11.81	13.78	15.75	17.72	19.69	21.65	23.62	25.59
27.56	29.53	31.50	33.46	35.43	37.40	39.37	41.34	43.31
45.28	47.24							

*Some face widths are not available in all horsepower. For minimum available face widths refer to TM127 Specifications.

**Idler dimensions are identical to the drum motor with no junction box.

Bracket AB 25

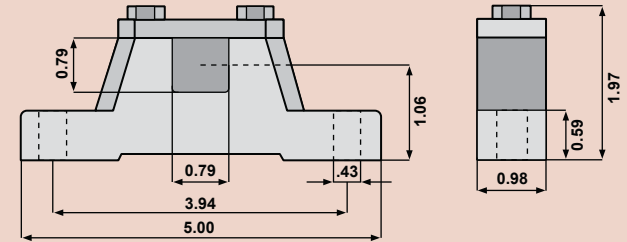

Optional Cable Type

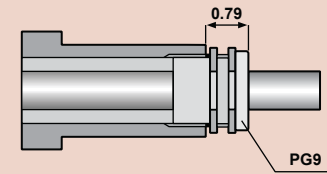

Note: When Optional Cable Type is selected, the minimum face width (L) increases by 1.969 inches.

1.5 HP

V (ft/min) M/G	316 4/S2	237 4/S2	201 4/S2	124 4/S2
Belt Pull (lbs)	156	207	244	396
Drum RPM	243	182	155	95

1.0 HP

V (ft/min) M/G	646 2/S2	484 2/S2	411 2/S2	316 4/S2	237 4/S2	201 4/S2	147 4/S2	124 4/S2	110 4/S2	73 4/PL2	58 4/PL2	49 4/PL2	38 4/PL2
Belt Pull (lbs)	51	68	80	104	138	163	223	264	298	449	565	669	767
Drum RPM	497	372	316	243	182	155	113	95	85	56	45	38	29

0.75 HP

V (ft/min) M/G	651 2/S2	488 2/S2	414 2/S2	328 4/S2	246 4/S2	209 4/S2	152 4/S2	134 4/S3	114 4/S2	97 4/S2	87 6/S2	74 6/S2	62 4/S3	56 4/S3	50 4/PL2
Belt Pull (lbs)	38	50	59	75	100	118	162	183	216	253	282	332	366	408	491
Drum RPM	501	375	318	252	189	161	117	103	88	75	67	57	48	43	38

V (ft/min) M/G	40 4/PL2
Belt Pull (lbs)	614
Drum RPM	31

0.5 HP

V (ft/min) M/G	321 4/S2	241 4/S2	205 4/S2	149 4/S2	131 4/S2	98 4/S2	83 4/S2	64 6/S2	54 4/S3	41 4/S3	33 6/PL2	26 6/PL2
Belt Pull (lbs)	51	68	80	110	125	167	197	256	303	400	496	630
Drum RPM	247	185	158	115	101	75	64	49	42	32	25	20

0.34 HP

V (ft/min) M/G	322 4/S2	241 4/S2	205 4/S2	149 4/S2	131 4/S2	99 4/S2	84 4/S2	61 4/S3	54 4/S3	41 4/S3
Belt Pull (lbs)	35	46	54	75	85	113	133	183	206	272
Drum RPM	248	185	158	115	101	76	65	47	42	32

0.25 HP

V (ft/min) M/G	11.1 4/PL3	8.7 4/PL3	7.3 4/PL3	5.8 4/PL3
Belt Pull (lbs)	738	767	767	767
Drum RPM	8.5	6.7	5.6	4.5

V = Belt Speed (ft/min)

M/G = Motor/Gear Reducer Configuration (at rated horsepower)

High Speed
Low Torque



Low Speed
High Torque

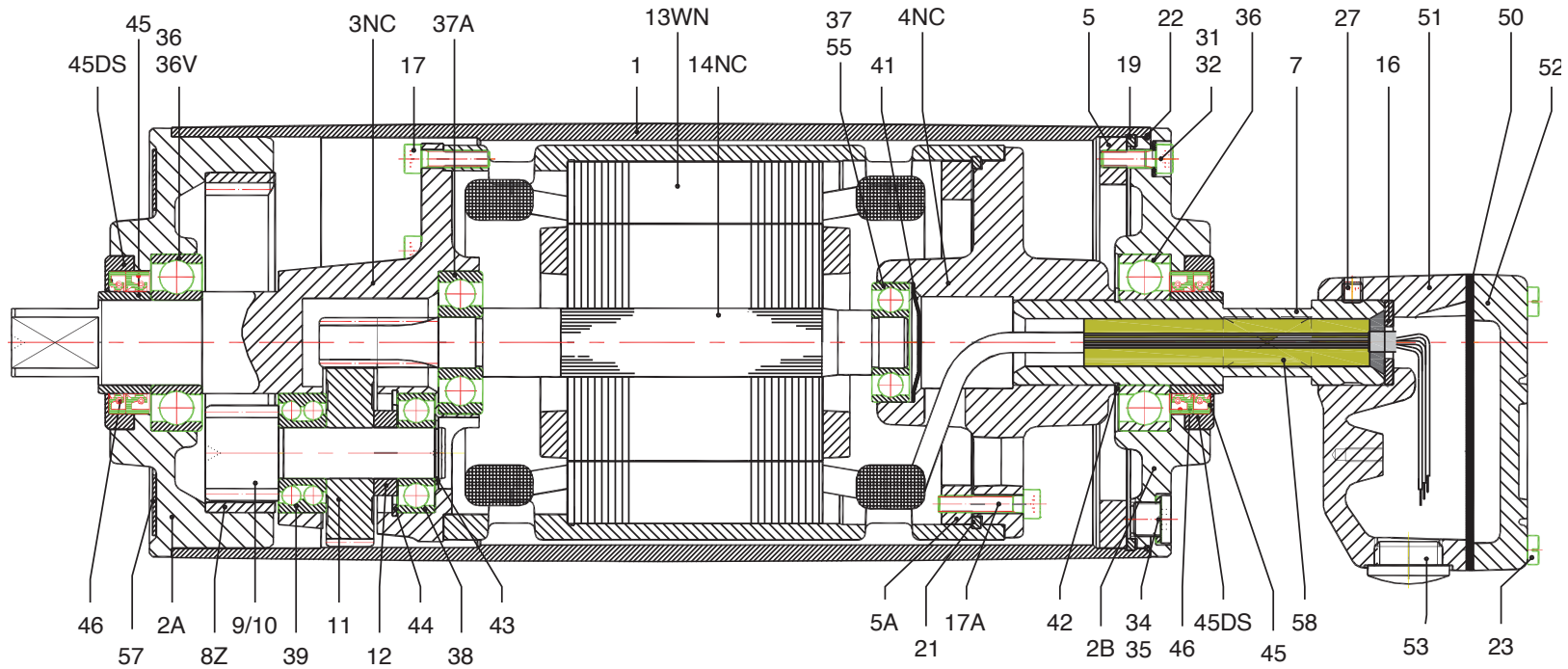

ITEM	PART DESCRIPTION	ITEM	PART DESCRIPTION	ITEM	PART DESCRIPTION	ITEM	PART DESCRIPTION
1	Shell	17	Socket Head Cap Screw	38	Ball Bearing	58	Epoxy Resin
2A	End Flange	17A	Socket Head Cap Screw	39	Needle Bearing		
2B	End Flange	19	Spring Ring	41	Disc		
3NC	Gear Housing	21	Spring Ring	42	Snap Ring		
4NC	Motor Flange	22	O-Ring	43	Snap Ring		
5	Mounting Ring	23	Fillister head Machine Screw	44	Snap Ring		
5A	Mounting Ring	27	Set Screw	45	Bearing race		
7	Hollow Shaft	31	Socket Head Cap Screw	45 DS	Double Seal Adapter		
8Z	Internal Gear	32	Bonded Seal Washer	46	Oil Seal		
9/10	Pinion with Bushing	34	Filler Plug	50	Seal		
11	Gear	35	Washer	51	Junction Box		
12	Distance Ring	36	Ball Bearing	52	Junction Box Cover		
13WN	Stator	36 V	Cylindrical Roller Bearing	53	Plug		
14NC	Rotor	37	Ball Bearing	55	Backstop Bearing - Optional		
16	Nitrile Gasket	37 A	Ball Bearing	57	Data Plate		