

TM113B25 Drum Motor (matching Idler KT113B25**)

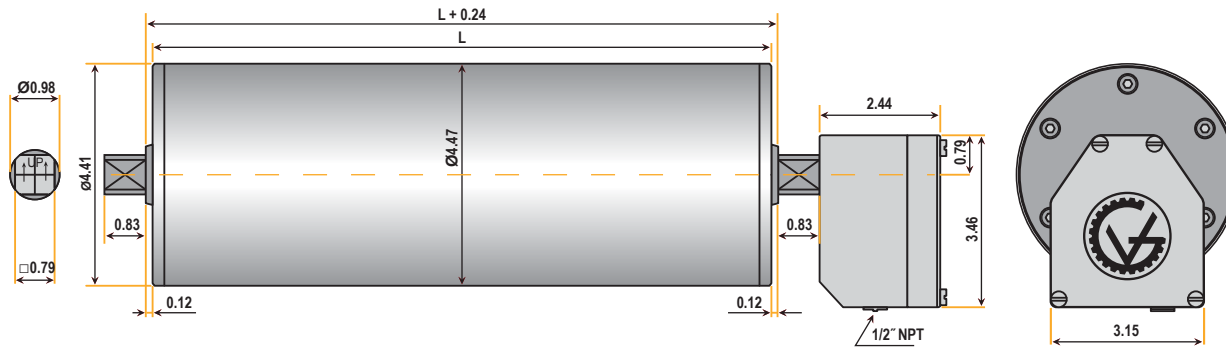

Standard drum motor face widths* (L) in inches:

10.24	10.83	12.20	14.17	16.14	18.11	20.08	22.05	24.02
25.98	27.95	29.92	31.89	33.86	35.83	37.80	39.76	41.73
43.70	45.67							

Bracket AB 20

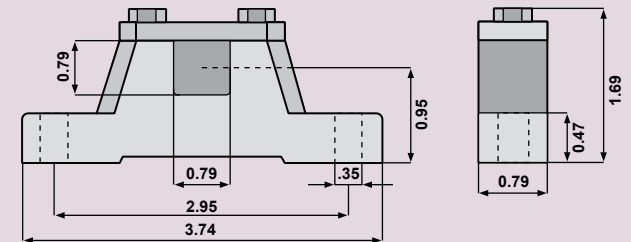

Optional Cable Type

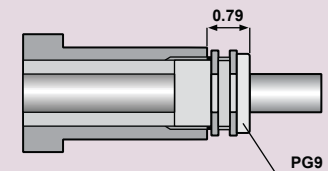

Note: When Optional Cable Type is selected, the minimum face width (L) increases by 1.969 inches.

*Some face widths are not available in all horsepower. For minimum available face widths refer to TM113 Specifications.

**Idler dimensions are identical to the drum motor with no junction box.

0.75 HP

V (ft/min) M/G	1039 2/S2	945 2/S2	756 2/S2	661 2/S2	591 2/S2	520 2/S2	449 2/S2
Belt Pull (lbs)	22	24	31	35	39	45	50
Drum RPM	1211	1100	880	770	688	605	523

0.5 HP

V (ft/min) M/G	1039 2/PL2	945 2/S2	756 2/S2	661 2/S2	591 2/S2
Belt Pull (lbs)	15	17	21	23	26
Drum RPM	1211	1100	880	770	688

0.5 HP

V (ft/min) M/G	520 4/S2	472 4/S2	378 4/S2	331 4/S2	295 4/S2	260 4/S2	224 4/S2	201 4/PL2	177 4/S2	165 4/PL2	154 4/PL2	142 4/S2	130 4/PL2	118 4/PL2	106 4/PL2
Belt Pull (lbs)	30	33	41	47	52	60	69	75	88	91	98	109	116	127	141
Drum RPM	605	550	440	385	344	303	261	234	206	193	179	165	151	138	124

V (ft/min) M/G	94 4/PL2	80 4/PL2	64 4/PL2
Belt Pull (lbs)	161	187	215
Drum RPM	110	94	74

0.34 HP

V (ft/min) M/G	1039 2/S2	945 2/S2	756 2/S2	661 2/S2	591 2/S2
Belt Pull (lbs)	10	11	14	16	18
Drum RPM	1211	1100	880	770	688

0.34 HP

V (ft/min) M/G	520 4/S2	472 4/S2	378 4/S2	331 4/S2	295 4/S2	260 4/S2	224 4/S2	201 4/PL2	177 4/PL2	165 4/PL2	154 4/PL2	130 4/PL2	118 4/PL2	106 4/PL2	94 4/PL2
Belt Pull (lbs)	21	22	28	32	36	40	47	50	57	62	66	79	86	95	108
Drum RPM	605	550	440	385	344	303	261	234	206	193	179	151	138	124	110

V (ft/min) M/G	80 4/PL2	64 4/PL2
Belt Pull (lbs)	126	159
Drum RPM	94	74

V = Belt Speed (ft/min)

M/G = Motor/Gear Reducer Configuration (at rated horsepower)

High Speed
Low Torque



Low Speed
High Torque

TM113 SERIES (4.5" diameter)



SPECIFICATIONS

0.34 HP

V (ft/min) M/G	236 6/S2	213 6/S2	189 6/S2	165 6/S2	142 6/S2	118 6/S2	94 6/S2	69 6/PL2	59 6/PL2	50 6/PL2	40 6/PL2
Belt Pull (lbs)	45	50	55	64	74	89	111	149	172	205	215
Drum RPM	275	248	220	193	165	138	110	80	69	58	47

0.25 HP

V (ft/min) M/G	378 4/S2	331 4/S2	295 4/S2	260 4/S2	224 4/S2	201 4/PL2	177 4/PL2	165 4/PL2	154 4/PL2	130 4/PL2	118 4/PL2	106 4/PL2	94 4/PL2	80 4/PL2	64 4/PL2
Belt Pull (lbs)	20	22	25	29	34	36	41	44	48	56	62	69	78	91	115
Drum RPM	440	385	344	303	261	234	206	193	179	151	138	124	110	94	74

V (ft/min) M/G	47 4/PL3	43 4/PL3	38 4/PL3	31 4/PL3	26 4/PL3
Belt Pull (lbs)	148	165	185	215	215
Drum RPM	55	50	44	36	30

0.25 HP

V (ft/min) M/G	213 6/S2	189 6/S2	165 6/S2	142 6/S2	59 6/PL2	50 6/PL2	40 6/PL2
Belt Pull (lbs)	36	40	46	53	123	148	182
Drum RPM	248	220	193	165	69	58	47

0.16 HP

V (ft/min) M/G	260 4/S2	224 4/S2	201 4/PL2	177 4/PL2	165 4/PL2	154 4/PL2	130 4/PL2	118 4/PL2	106 4/PL2	94 4/PL2	80 4/PL2	64 4/PL2	43 4/PL3	26 4/PL3	17 4/PL3
Belt Pull (lbs)	20	22	24	27	30	32	37	41	46	51	61	77	109	180	215
Drum RPM	303	261	234	206	193	179	151	138	124	110	94	74	50	30	19

V = Belt Speed (ft/min)

M/G = Motor/Gear Reducer Configuration (at rated horsepower)

High Speed
Low Torque



Low Speed
High Torque

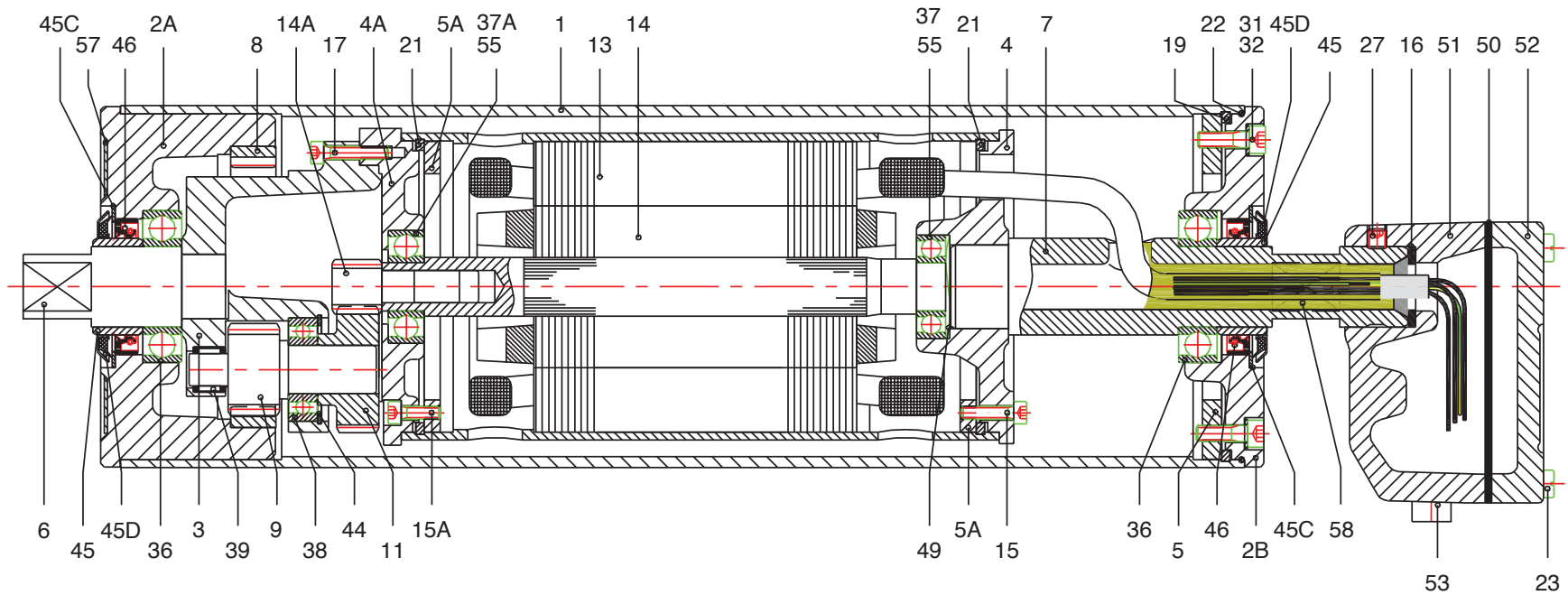

ITEM	PART DESCRIPTION	ITEM	PART DESCRIPTION	ITEM	PART DESCRIPTION
1	Shell	14 A	Insert Pinion	38	Ball Bearing
2A	End Flange	15	Socket Head Cap Screw	39	Needle Bearing
2B	End Flange	15 A	Socket Head Cap Screw	44	Snap Ring
3	Gear Housing	16	Nitrile Gasket	45	Bearing race
4	Motor Flange	17	Socket Head Cap Screw	45 C	Shim plate
4 A	Motor Flange	19	Spring Ring	45 D	Gamma Ring
5	Mounting Ring	21	Spring Ring	46	Oil Seal
5 A	Mounting Ring	22	O-Ring	49	Wave Washer
6	Shaft End	23	Fillister head Machine Screw	50	Seal
7	Hollow Shaft	27	Set Screw	51	Junction Box
8	Internal Gear	31	Socket Head Cap Screw	52	Junction Box Cover
9	Pinion	32	Bonded Seal Washer	53	Plug
11	Gear	36	Ball Bearing	55	Backstop Bearing (Optional)
13	Stator	37	Ball Bearing	57	Name Plate
14	Rotor	37 A	Ball Bearing	58	Epoxy Resin